

PLANNING FOR TRASH

A REGIONAL LOOK AT MUNICIPAL PERCEPTIONS OF SOLID WASTE MANAGEMENT IN URBAN PLANNING

By Maria-Louise Javier

March 21, 2017



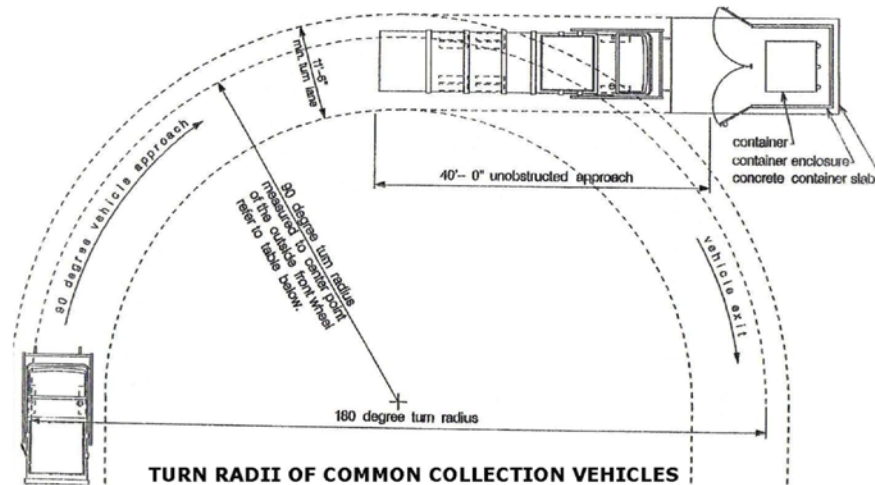
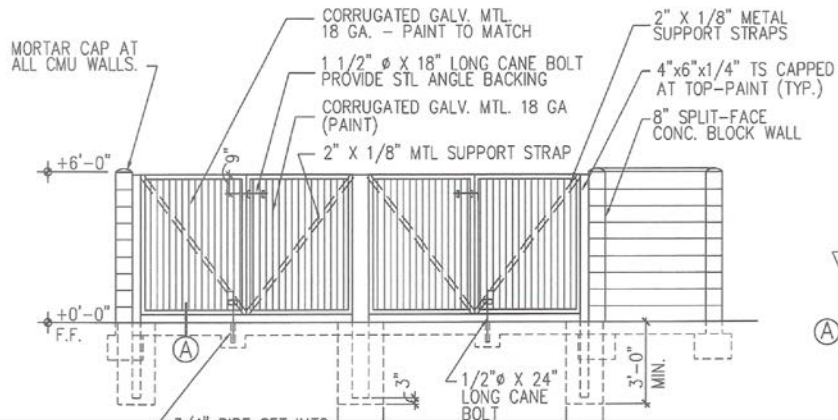

TURN RADII OF COMMON COLLECTION VEHICLES

TRAVEL HEIGHT	= 4.3 M
MAX WORKING HEIGHT	= 6.16 M
MAX OPERATING WEIGHT	= 27.5 TON
MAX WIDTH	= 2.49 M
TURNING CIRCLE RADII	
WALL TO WALL	= 10.1 M
KERB TO KERB	= 9.3 M
INSIDE OF TRUCK	= 4.8 M

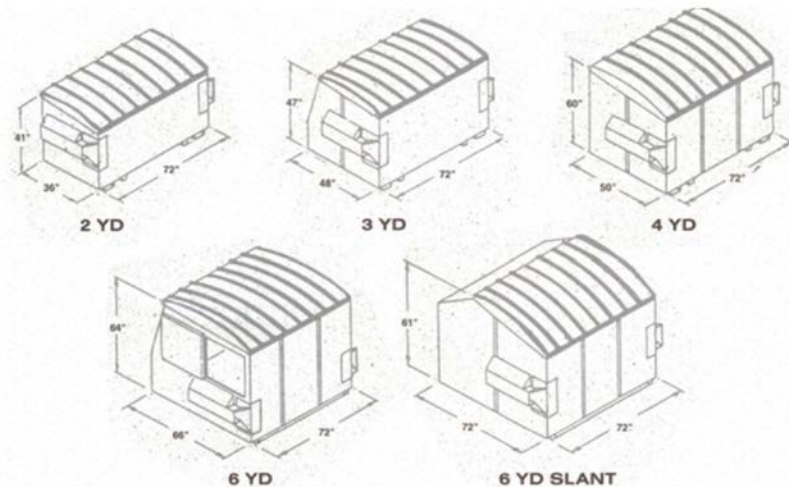
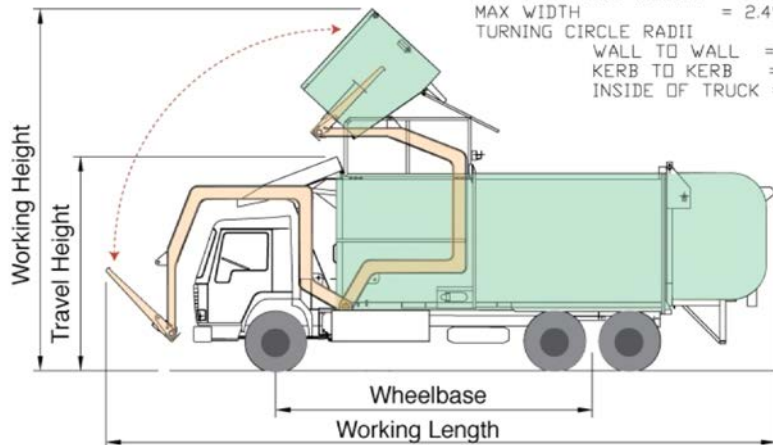

AGENDA

- Background of the Study
- Overview of Effective Tools
- Tools One-By-One
- Considerations
- What We Learned

- Summer 2015
- Documents & interviews
- Commercial development

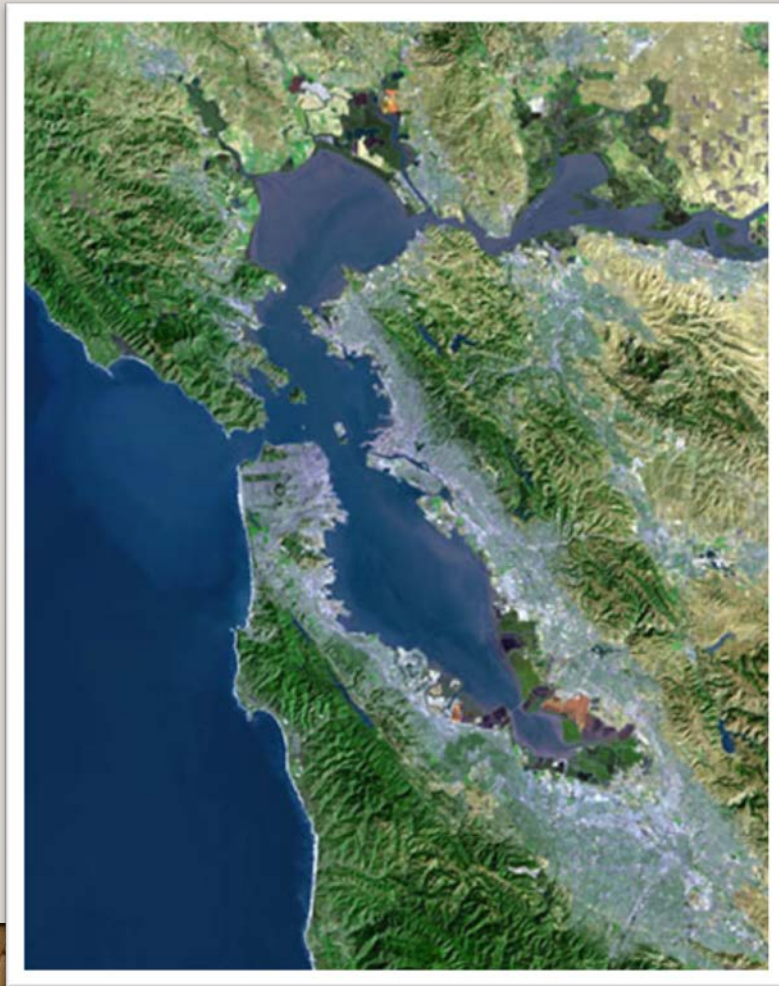

Selection Based On:

1. Population=
100K – 200K
2. Practicing IWM
3. NPDES
Stormwater
Permit

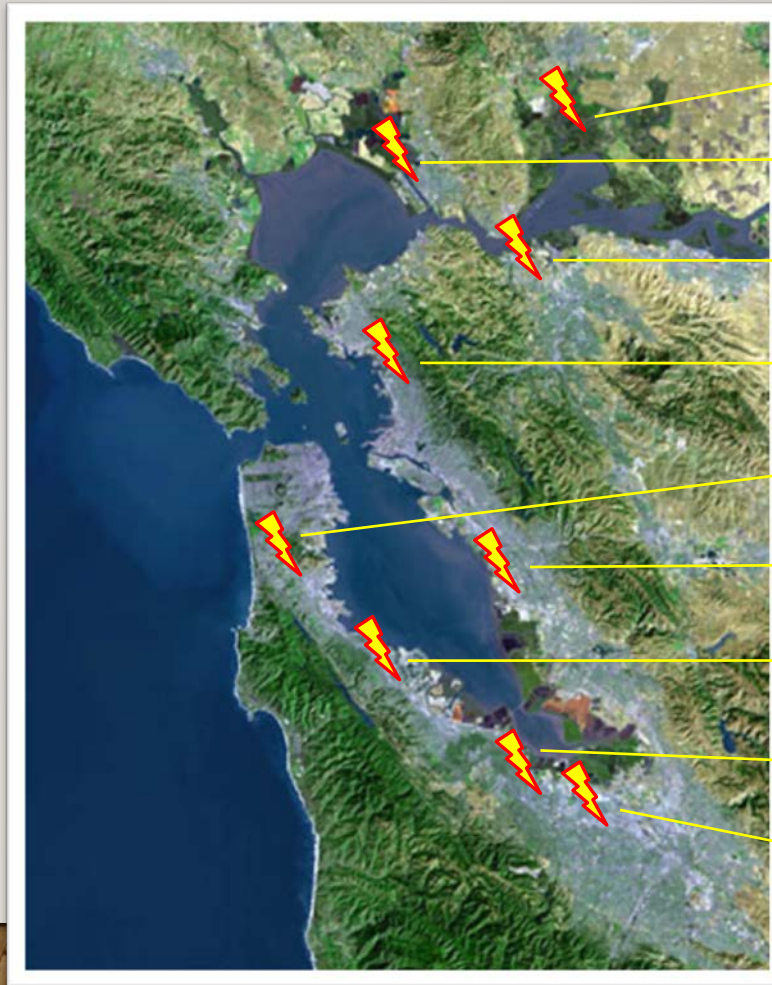

Concord

Vallejo

Fairfield

Berkeley

Daly City

Hayward

San Mateo

Sunnyvale

Santa Clara

MOST EFFECTIVE TOOLS

1. Inclusion in the process
2. Accessible information
3. Technical programs
4. Staff training
5. Leadership

I. INCLUSION IN THE PROCESS

- Project routing
- Meetings
- Checklists
- Municipal codes

“It’s much easier if staff can point to the code and say, ‘You’re required to do it’ rather than ‘Please do it.’”

-Leigha Schmidt (Senior Planner AICP, City of Hayward)

2. ACCESSIBLE INFORMATION

- Clarity
- Distribution
- Accessibility
- Stand-alone document

“It’s something you can share with the developers, with the planners. It’s a one-stop-shop when it comes to solid waste.”

-City of Santa Clara staff

3. TECHNICAL PROGRAMS

- Project tracking
- Programmed alerts
- Coordination across systems

“With this new automation between the two systems, we’ve already probably realized an efficiency gain of approximately one half to one full-time equivalent staff person from this program.”

-City of Palo Alto staff

4. STAFF TRAINING

- Technical programs
- Cross-discipline knowledge
- Clear, consistent feedback

“We need to achieve that extra level of collaboration in order to speak consistently and coherently to the developer in what we’re looking for and what we need.”

-Jeff Schwilk (Associate Planner AICP, City of Santa Clara)

5. LEADERSHIP

- Support from management
- Build effective relationships

“I think any time you can prove that a relationship is mutually beneficial, after time it tends to warm up.”

-Jennifer Yee (Sustainability Technician, City of Hayward)

CONSIDERATIONS

1. Limited staff time and resources
2. Single source vs. division of labor
3. New program requirements
4. Hauler contracts
5. Public response

WHAT WE LEARNED

TOOLS:

- ✓ Inclusion in the process
- ✓ Accessible information
- ✓ Technical programs
- ✓ Staff training
- ✓ Leadership

CONSIDERATIONS:

- ✓ Limited staff time and resources
- ✓ Single source vs. division of labor
- ✓ New program requirements
- ✓ Hauler contracts
- ✓ Public response





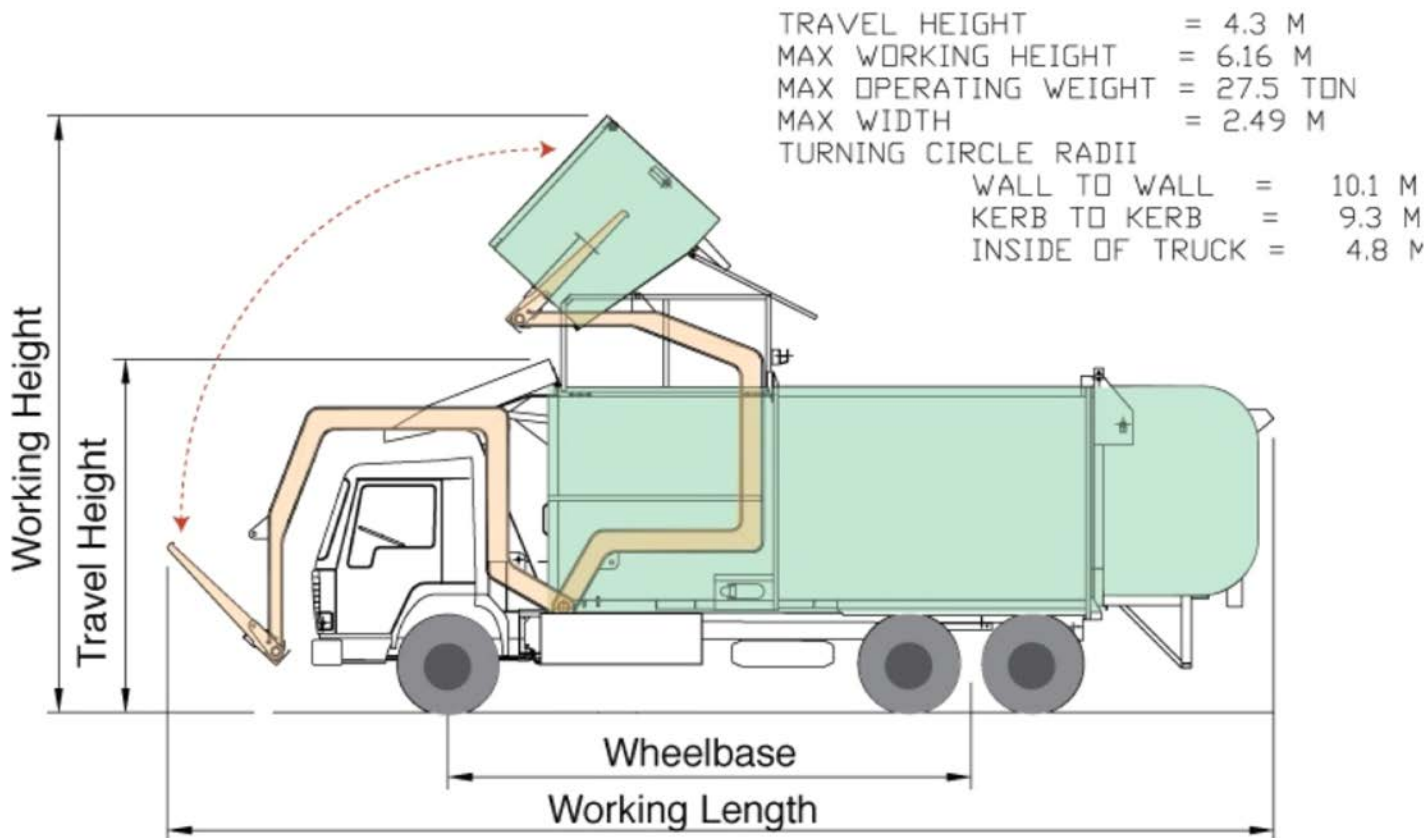









THANK YOU!

Noren Caliva-Lepe, *Associate Planner, Sunnyvale*

Derek Crutchfield, *Recycling Coordinator, Vallejo*

Robert Harvie, *Solid Waste Specialist, Sunnyvale*

Matthew Krupp, *Environmental Programs Manager – Zero Waste, Palo Alto*

Leigha Schmidt, *Senior Planner AICP, Hayward*

Jeff Schwilk, *Associate Planner AICP, Santa Clara*

Jennifer Yee, *Sustainability Technician, Hayward*

City of Daly City staff

City of Fairfield staff

City of Palo Alto staff

City of Santa Clara staff

City of Vallejo staff

Questions?

Email: mljavier12@gmail.com

Website: www.earthplanningmlj.com